

This document, together with the concepts and designs presented herein, is intended only for the specific purpose and client for which it was prepared. Reuse of and improper reliance on this document without written authorization and adaptation by Kinney-Horn and Associates, Inc. shall be without liability to Kinney-Horn and Associates, Inc.

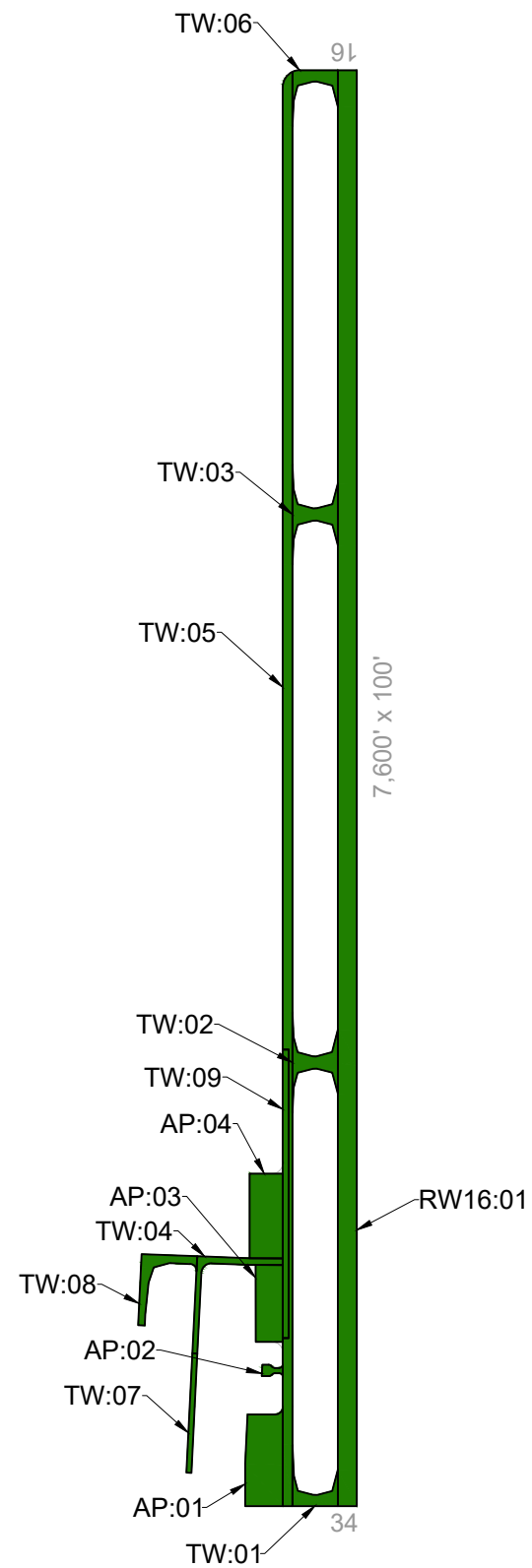

LEGEND

—	BRANCH IDENTIFIER
—	SECTION IDENTIFIER
—	SECTION BOUNDARY
■ (Dark Green)	PCI 86-100 GOOD
■ (Light Green)	PCI 71-85 SATISFACTORY
■ (Yellow)	PCI 56-70 FAIR
■ (Orange)	PCI 41-55 POOR
■ (Pink)	PCI 26-40 VERY POOR
■ (Red)	PCI 11-25 SERIOUS
■ (Grey)	PCI 0-10 FAILED

CURRENT 2024 PAVEMENT CONDITION INDEX

Branch ID	Section ID	Branch Name	Surface Type	Section Area (SF)	Approx. Age at Inspection	Last Major Work Date	Last Inspection Date	Pavement Condition Index	PCI Category
RW16	01	Runway 16-34	AC	759,721	4.9	1/1/2020	10/7/2024	94	Good
TW	01	Taxiway	AC	20,910	4.9	1/1/2020	10/7/2024	91	Good
TW	02	Taxiway	AC	28,540	4.9	1/1/2020	10/7/2024	89	Good
TW	03	Taxiway	AC	28,163	4.9	1/1/2020	10/7/2024	89	Good
TW	04	Taxiway	AC	28,831	8	11/1/2016	10/7/2024	89	Good
TW	05	Taxiway	AC	344,557	4.9	1/1/2020	10/7/2024	90	Good
TW	06	Taxiway	AC	20,439	4.9	1/1/2020	10/7/2024	88	Good
TW	07	Taxiway	AC	16,429	4.9	1/1/2020	10/7/2024	94	Good
TW	08	Taxiway	AC	28,685	4.9	1/1/2020	10/7/2024	90	Good
TW	09	Taxiway	AAC	28,685	2.9	1/1/2022	10/7/2024	91	Good
AP	01	Apron	AC	94,830	4.9	1/1/2020	10/7/2024	89	Good
AP	02	Apron	AC	4,840	4.9	1/1/2020	10/7/2024	90	Good
AP	03	Apron	AC	57,794	8	11/1/2016	10/7/2024	87	Good
AP	04	Apron	AC	78,400	8	11/1/2016	10/7/2024	89	Good

AIRFIELD PAVEMENT WORK HISTORY

1. AIP-002-1990, ALL NEW CONSTRUCTION
2. AIP-003-1992, CONSTRUCT PARALLEL TAXIWAY EXTENSION, APRON AND ACCESS TAXIWAY.
3. AIP-005-2001, CRACK SEAL, FOG SEAL, AND REMARK ALL PAVEMENTS.
4. AIP-010-2008, RECONSTRUCT RUNWAY (RW16:01); CONSTRUCT RUNWAY EXTENSION AND TURN AROUND; CRACK SEAL, FOG SEAL, AND REMARK ALL REMAINING PAVEMENTS.
5. AIP-012-2013, CRACK SEAL, FOG SEAL, AND REMARK ALL PAVEMENTS.
6. AIP-015-2015, CONSTRUCT APRON (AP:04) AND TAXIWAY (TW:03), RECONSTRUCT APRON (AP:03) AND TAXIWAY (TW:04).
7. AIP-021-2020, RECONSTRUCT AND EXTEND RUNWAY (RW16:01). REALIGN AND RECONSTRUCT TAXIWAY (TW:05, TW:03). RECONSTRUCT APRON (AP:01, AP:02) AND TAXIWAY (TW:01, TW:02). CONSTRUCT TAXIWAY (TW:06, TW:07, TW:08).
8. AIP-021-2020, SEAL COAT APRON (AP:03, AP:04) AND TAXIWAY (TW:09) [2022].



This document, together with the concepts and designs presented herein, is an instrument of service, is intended only for the specific purpose and client for which it was prepared. Reuse of and improper reliance on this document without written authorization and adaptation by Kinney-Horn and Associates, Inc. shall be without liability to Kinney-Horn and Associates, Inc.

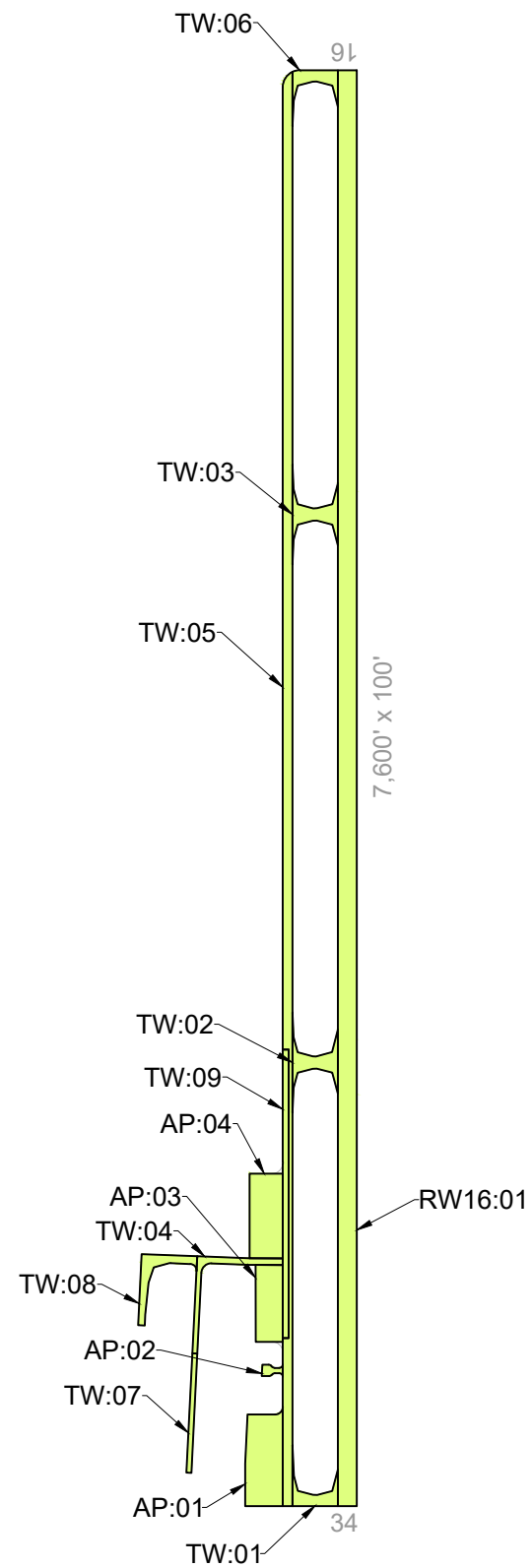

LEGEND

- BRANCH IDENTIFIER
- RW01:10** — SECTION IDENTIFIER
- SECTION BOUNDARY
- PCI 86-100 GOOD
- PCI 71-85 SATISFACTORY
- PCI 56-70 FAIR
- PCI 41-55 POOR
- PCI 26-40 VERY POOR
- PCI 11-25 SERIOUS
- PCI 0-10 FAILED

FORECASTED PAVEMENT CONDITION INDEX

Branch ID	Section ID	Surface Type	Current PCI (2024)	2025	2026	2027	2028	2029
RW16	01	AC	94	93	91	88	86	84
TW	01	AC	91	90	88	86	84	82
TW	02	AC	89	88	86	84	83	81
TW	03	AC	89	88	86	84	83	81
TW	04	AC	89	88	86	84	83	81
TW	05	AC	90	89	87	85	83	82
TW	06	AC	88	87	85	84	82	80
TW	07	AC	94	93	91	88	86	84
TW	08	AC	90	89	87	85	83	82
TW	09	AAC	91	90	88	86	84	82
AP	01	AC	89	88	86	84	82	80
AP	02	AC	90	89	87	85	83	81
AP	03	AC	87	86	84	82	80	79
AP	04	AC	89	88	86	84	82	80



This document, together with the concepts and designs presented herein, is an instrument of service, is intended only for the specific purpose and client for which it was prepared. Reuse of and improper reliance on this document without written authorization and adaptation by Kinney-Horn and Associates, Inc. shall be without liability to Kinney-Horn and Associates, Inc.

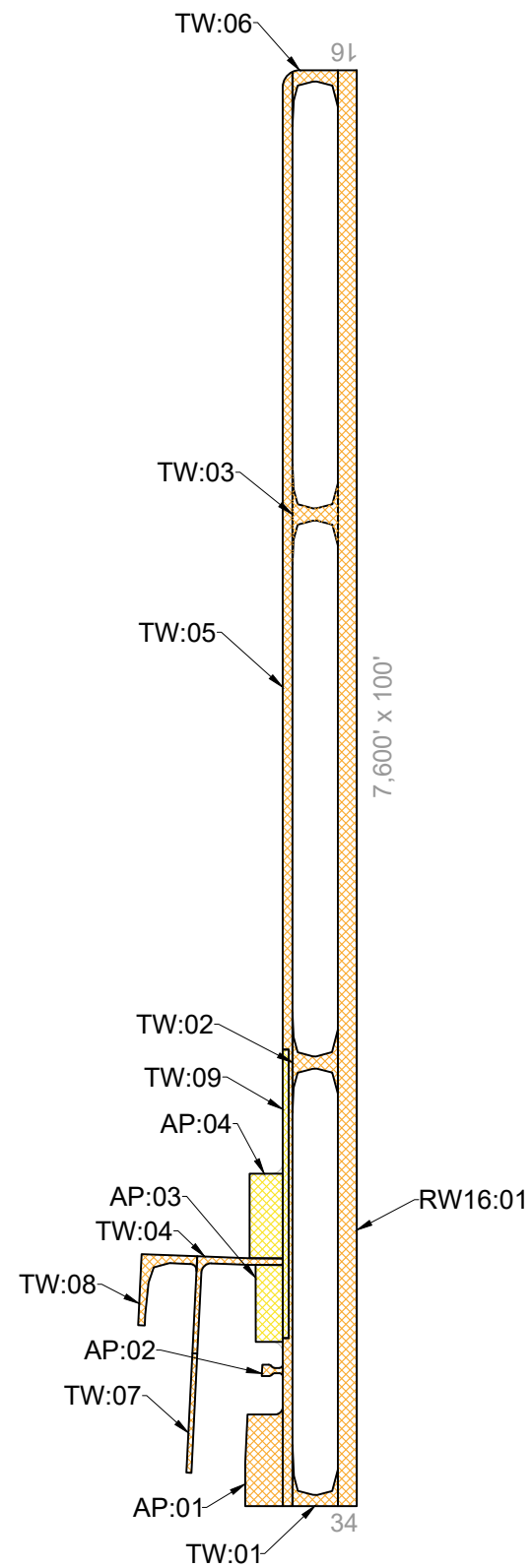

LEGEND

— BRANCH IDENTIFIER	
— SECTION IDENTIFIER	
— SECTION BOUNDARY	
RW01:10	
MAJOR REHABILITATION	GLOBAL TREATMENT
2025 (Orange)	2025 (Cross-hatch)
2026 (Blue)	2026 (Blue cross-hatch)
2027 (Yellow)	2027 (Yellow cross-hatch)
2028 (Purple)	2028 (Purple cross-hatch)
2029 (Red)	2029 (Red cross-hatch)

5-YEAR PAVEMENT NEEDS BY SECTION

Year	Branch ID	Section ID	Surface Type	Section Area (SF)	PCI at Treatment	Recommended Treatment	Treatment Category
2025	RW16	01	AC	759,721	93	Crack Seal and Seal Coat	Global Treatment
2025	TW	01	AC	20,910	90	Crack Seal and Seal Coat	Global Treatment
2025	TW	02	AC	28,540	88	Crack Seal and Seal Coat	Global Treatment
2025	TW	03	AC	28,163	88	Crack Seal and Seal Coat	Global Treatment
2025	TW	04	AC	28,831	88	Crack Seal and Seal Coat	Global Treatment
2025	TW	05	AC	344,557	89	Crack Seal and Seal Coat	Global Treatment
2025	TW	06	AC	20,439	87	Crack Seal and Seal Coat	Global Treatment
2025	TW	07	AC	16,429	93	Crack Seal and Seal Coat	Global Treatment
2025	TW	08	AC	28,685	89	Crack Seal and Seal Coat	Global Treatment
2025	AP	01	AC	94,830	88	Crack Seal and Seal Coat	Global Treatment
2025	AP	02	AC	4,840	89	Crack Seal and Seal Coat	Global Treatment
2027	TW	09	AAC	28,685	86	Crack Seal and Seal Coat	Global Treatment
2027	AP	03	AC	57,794	82	Crack Seal and Seal Coat	Global Treatment
2027	AP	04	AC	78,400	84	Crack Seal and Seal Coat	Global Treatment

Runway



RW16-01-58: Weathering



RW16-01-73: Weathering

Taxiway



TW-05-66: Weathering



TW-06-03: L&T Cracking

Apron



AP-01-11: L&T Cracking



AP-04-09: Weathering

Re-Inspection Report

MDT SASP 2024

Generated Date 1/7/2025

Page 1 of 14

Network: EKS **Name:** Ennis - Big Sky Airport

Branch: AP **Name:** Apron **Use:** APRON **Area:** 235,864 SqFt

Section: 01 of 4 **From:** TW-05 **To:** End **Last Const.:** 1/1/2020

Surface: AC **Family:** _MDT2024 - AP AC **Zone:** **Category:** **Rank:** P

Area: 94,830 SqFt **Length:** 526 Ft **Width:** 198 Ft

Slabs: **Slab Length:** Ft **Slab Width:** Ft **Joint Length:** Ft

Shoulder: **Street Type:** **Grade:** 0 **Lanes:** 0

Section Comments:

Work Date: 1/1/2020 **Work Type:** New Construction - AC **Code:** NC-AC **Is Major M&R:** True

Last Insp. Date: 10/7/2024 **TotalSamples:** 20 **Surveyed:** 5

Conditions: PCI: 89

Inspection Comments:

Sample Number: 03 **Type:** R **Area:** 4554.00 SqFt **PCI:** 91

Sample Comments:

48 L & T CR L 8.00 Ft
57 WEATHERING L 4554.00 SqFt

Sample Number: 07 **Type:** R **Area:** 4900.00 SqFt **PCI:** 89

Sample Comments:

48 L & T CR L 44.00 Ft
57 WEATHERING L 4900.00 SqFt

Sample Number: 11 **Type:** R **Area:** 3861.00 SqFt **PCI:** 84

Sample Comments:

48 L & T CR L 135.00 Ft
57 WEATHERING L 3861.00 SqFt

Sample Number: 15 **Type:** R **Area:** 5000.00 SqFt **PCI:** 94

Sample Comments:

57 WEATHERING L 5000.00 SqFt

Sample Number: 19 **Type:** R **Area:** 5000.00 SqFt **PCI:** 88

Sample Comments:

48 L & T CR L 94.00 Ft
57 WEATHERING L 5000.00 SqFt

Network:	EKS	Name:	Ennis - Big Sky Airport					
Branch:	AP	Name:	Apron	Use:	APRON	Area:	235,864 SqFt	
Section:	02	of 4	From:	TW-05	To:	End	Last Const.:	1/1/2020
Surface:	AC	Family:	_MDT2024 - AP AC	Zone:		Category:	Rank:	P
Area:	4,840 SqFt	Length:	110 Ft	Width:	60 Ft			
Slabs:		Slab Length:	Ft	Slab Width:	Ft	Joint Length:	Ft	
Shoulder:		Street Type:		Grade:	0	Lanes:	0	
Section Comments:								
Work Date:	1/1/2020	Work Type:	New Construction - AC		Code:	NC-AC	Is Major M&R:	True
Last Insp. Date:	10/7/2024	TotalSamples:	1		Surveyed:	1		
Conditions:	PCI: 90							
Inspection Comments:								
Sample Number:	01	Type:	R	Area:	4840.00 SqFt	PCI:	90	
Sample Comments:								
48	L & T CR	L	21.00 Ft					
57	WEATHERING	L	4840.00 SqFt					

Network:	EKS	Name:	Ennis - Big Sky Airport						
Branch:	AP	Name:	Apron	Use:	APRON	Area:	235,864 SqFt		
Section:	03	of 4	From:	TW-05	To:	HANGARS	Last Const.:	11/1/2016	
Surface:	AC	Family:	_MDT2024 - AP AC	Zone:		Category:		Rank:	P
Area:	57,794 SqFt	Length:	407 Ft	Width:	142 Ft				
Slabs:		Slab Length:	Ft	Slab Width:	Ft	Joint Length:	Ft		
Shoulder:		Street Type:		Grade:	0	Lanes:	0		
Section Comments:	Southern Portion of large apron split by TW-06								
Work Date:	11/1/2016	Work Type:	New Construction - AC		Code:	NC-AC	Is Major M&R:	True	
Work Date:	1/1/2022	Work Type:	Surface Seal - Seal Coat		Code:	SS-SC	Is Major M&R:	False	
Last Insp. Date:	10/7/2024	TotalSamples:	11	Surveyed:	4				
Conditions:	PCI: 87								
Inspection Comments:									
Sample Number:	02	Type:	R	Area:	5254.00 SqFt	PCI:	86		
Sample Comments:									
48	L & T CR	L	37.00	Ft					
57	WEATHERING	L	4991.00	SqFt					
57	WEATHERING	M	263.00	SqFt					
Sample Number:	05	Type:	R	Area:	5260.00 SqFt	PCI:	91		
Sample Comments:									
57	WEATHERING	L	4997.00	SqFt					
57	WEATHERING	M	263.00	SqFt					
Sample Number:	08	Type:	R	Area:	5254.00 SqFt	PCI:	87		
Sample Comments:									
48	L & T CR	L	22.00	Ft					
57	WEATHERING	L	4991.00	SqFt					
57	WEATHERING	M	263.00	SqFt					
Sample Number:	11	Type:	R	Area:	5254.00 SqFt	PCI:	86		
Sample Comments:									
48	L & T CR	L	71.00	Ft					
57	WEATHERING	L	4991.00	SqFt					
57	WEATHERING	M	263.00	SqFt					

Network:	EKS	Name:	Ennis - Big Sky Airport						
Branch:	AP	Name:	Apron	Use:	APRON	Area:	235,864 SqFt		
Section:	04	of 4	From:	TW-05	To:	End	Last Const.:	11/1/2016	
Surface:	AC	Family:	_MDT2024 - AP AC	Zone:		Category:		Rank:	P
Area:	78,400 SqFt	Length:	448 Ft	Width:	175 Ft				
Slabs:		Slab Length:	Ft	Slab Width:	Ft	Joint Length:	Ft		
Shoulder:		Street Type:		Grade:	0	Lanes:	0		
Section Comments:	Northern portion of large apron split by TW-06								
Work Date:	11/1/2016	Work Type:	New Construction - AC		Code:	NC-AC	Is Major M&R:	True	
Work Date:	1/1/2022	Work Type:	Surface Seal - Seal Coat		Code:	SS-SC	Is Major M&R:	False	
Last Insp. Date:	10/7/2024	TotalSamples:	16	Surveyed:	5				
Conditions:	PCI: 89								
Inspection Comments:									
Sample Number:	01	Type:	R	Area:	4900.00 SqFt	PCI:	84		
Sample Comments:									
48	L & T CR	L	53.00	Ft					
50	PATCHING	L	6.00	SqFt					
57	WEATHERING	L	4649.00	SqFt					
57	WEATHERING	M	245.00	SqFt					
Sample Number:	05	Type:	R	Area:	4900.00 SqFt	PCI:	91		
Sample Comments:									
57	WEATHERING	L	4655.00	SqFt					
57	WEATHERING	M	245.00	SqFt					
Sample Number:	09	Type:	R	Area:	4879.00 SqFt	PCI:	91		
Sample Comments:									
57	WEATHERING	L	4635.00	SqFt					
57	WEATHERING	M	244.00	SqFt					
Sample Number:	13	Type:	R	Area:	4900.00 SqFt	PCI:	91		
Sample Comments:									
57	WEATHERING	L	4655.00	SqFt					
57	WEATHERING	M	245.00	SqFt					
Sample Number:	15	Type:	R	Area:	4900.00 SqFt	PCI:	87		
Sample Comments:									
48	L & T CR	L	10.00	Ft					
57	WEATHERING	L	4655.00	SqFt					
57	WEATHERING	M	245.00	SqFt					

Network:	EKS	Name:	Ennis - Big Sky Airport						
Branch:	RW16	Name:	Runway 16-34	Use:	RUNWAY	Area:	759,721 SqFt		
Section:	01	of	1	From:	South End	To:	North End	Last Const.:	1/1/2020
Surface:	AC	Family:	_MDT2024 - RW AC AAC	Zone:	ENNI	Category:	D	Rank:	P
Area:	759,721 SqFt	Length:	7,600 Ft	Width:	100 Ft				
Slabs:		Slab Length:	Ft	Slab Width:	Ft	Joint Length:	Ft		
Shoulder:		Street Type:	ACM	Grade:	0	Lanes:	0		
Section Comments:									
Work Date:	7/31/1990	Work Type:	New Construction - Initial		Code:	NU-IN	Is Major M&R:	True	
Work Date:	1/1/2020	Work Type:	New Construction - AC		Code:	NC-AC	Is Major M&R:	True	
Last Insp. Date:	10/7/2024	TotalSamples:	152	Surveyed:	7				
Conditions:	PCI: 94								
Inspection Comments:									
Sample Number:	12	Type:	R	Area:	5000.00 SqFt	PCI:	94		
Sample Comments:									
57	WEATHERING		L	5000.00	SqFt				
Sample Number:	122	Type:	R	Area:	5000.00 SqFt	PCI:	94		
Sample Comments:									
57	WEATHERING		L	5000.00	SqFt				
Sample Number:	145	Type:	R	Area:	5000.00 SqFt	PCI:	94		
Sample Comments:									
57	WEATHERING		L	5000.00	SqFt				
Sample Number:	35	Type:	R	Area:	5000.00 SqFt	PCI:	94		
Sample Comments:									
57	WEATHERING		L	5000.00	SqFt				
Sample Number:	58	Type:	R	Area:	5000.00 SqFt	PCI:	94		
Sample Comments:									
57	WEATHERING		L	5000.00	SqFt				
Sample Number:	73	Type:	R	Area:	5000.00 SqFt	PCI:	94		
Sample Comments:									
57	WEATHERING		L	5000.00	SqFt				
Sample Number:	99	Type:	R	Area:	5000.00 SqFt	PCI:	94		
Sample Comments:									
57	WEATHERING		L	5000.00	SqFt				

Network:	EKS	Name:	Ennis - Big Sky Airport						
Branch:	TW	Name:	Taxiway	Use:	TAXIWAY	Area:	545,239 SqFt		
Section:	01	of 9	From:	TW-05	To:	RW16	Last Const.:	1/1/2020	
Surface:	AC	Family:	_MDT2024 - TW AC	Zone:	ENNI	Category:	D	Rank:	P
Area:	20,910 SqFt	Length:	240 Ft	Width:	70 Ft				
Slabs:	Slab Length:	Ft	Slab Width:	Ft	Joint Length:	Ft			
Shoulder:	Street Type:	ACM	Grade:	0	Lanes:	0			
Section Comments:	Southern most connector								
Work Date:	7/31/1990	Work Type:	New Construction - Initial		Code:	NU-IN	Is Major M&R:	True	
Work Date:	1/1/2020	Work Type:	Reconstruct with AC		Code:	RC-AC	Is Major M&R:	True	
Last Insp. Date:	10/7/2024	TotalSamples:	4	Surveyed:	3				
Conditions:	PCI:	91							
Inspection Comments:									
Sample Number:	01	Type:	R	Area:	5666.00 SqFt	PCI:	90		
Sample Comments:									
48	L & T CR	L	43.00	Ft					
57	WEATHERING	L	5666.00	SqFt					
Sample Number:	02	Type:	R	Area:	4966.00 SqFt	PCI:	90		
Sample Comments:									
48	L & T CR	L	34.00	Ft					
57	WEATHERING	L	4966.00	SqFt					
Sample Number:	03	Type:	R	Area:	4920.00 SqFt	PCI:	94		
Sample Comments:									
57	WEATHERING	L	4920.00	SqFt					

Network:	EKS	Name:	Ennis - Big Sky Airport					
Branch:	TW	Name:	Taxiway	Use:	TAXIWAY	Area:	545,239 SqFt	
Section:	02	of 9	From:	TW-05	To:	RW16-01	Last Const.:	1/1/2020
Surface:	AC	Family:	_MDT2024 - TW AC	Zone:		Category:	Rank:	P
Area:	28,540 SqFt	Length:	240 Ft	Width:	65 Ft			
Slabs:	Slab Length:	Ft	Slab Width:	Ft	Joint Length:	Ft		
Shoulder:	Street Type:		Grade:	0	Lanes:	0		
Section Comments:								
Work Date:	1/1/2020	Work Type:	New Construction - AC		Code:	NC-AC	Is Major M&R:	True
Last Insp. Date:	10/7/2024	TotalSamples:	6	Surveyed:	3			
Conditions:	PCI: 89							
Inspection Comments:								
Sample Number:	01	Type:	R	Area:	3964.00 SqFt	PCI:	89	
Sample Comments:								
48	L & T CR	L	60.00	Ft				
57	WEATHERING	L	3964.00	SqFt				
Sample Number:	03	Type:	R	Area:	6241.00 SqFt	PCI:	90	
Sample Comments:								
48	L & T CR	L	39.00	Ft				
57	WEATHERING	L	6241.00	SqFt				
Sample Number:	06	Type:	R	Area:	3993.00 SqFt	PCI:	87	
Sample Comments:								
48	L & T CR	L	83.00	Ft				
57	WEATHERING	L	3993.00	SqFt				

Network:	EKS	Name:	Ennis - Big Sky Airport					
Branch:	TW	Name:	Taxiway	Use:	TAXIWAY	Area:	545,239 SqFt	
Section:	03	of 9	From:	TW-05	To:	RW16-01	Last Const.:	1/1/2020
Surface:	AC	Family:	_MDT2024 - TW AC	Zone:		Category:	Rank:	P
Area:	28,163 SqFt	Length:	240 Ft	Width:	65 Ft			
Slabs:	Slab Length:	Ft	Slab Width:	Ft	Joint Length:	Ft		
Shoulder:	Street Type:		Grade:	0	Lanes:	0		
Section Comments:								
Work Date:	1/1/2020	Work Type:	New Construction - AC		Code:	NC-AC	Is Major M&R:	True
Last Insp. Date:	10/7/2024	TotalSamples:	6	Surveyed:	3			
Conditions:	PCI: 89							
Inspection Comments:								
Sample Number:	02	Type:	R	Area:	4098.00 SqFt	PCI:	89	
Sample Comments:								
48	L & T CR	L	34.00	Ft				
57	WEATHERING	L	4098.00	SqFt				
Sample Number:	03	Type:	R	Area:	5957.00 SqFt	PCI:	89	
Sample Comments:								
48	L & T CR	L	83.00	Ft				
57	WEATHERING	L	5957.00	SqFt				
Sample Number:	05	Type:	R	Area:	3938.00 SqFt	PCI:	87	
Sample Comments:								
48	L & T CR	L	87.00	Ft				
57	WEATHERING	L	3938.00	SqFt				

Network:	EKS	Name:	Ennis - Big Sky Airport						
Branch:	TW	Name:	Taxiway	Use:	TAXIWAY	Area:	545,239 SqFt		
Section:	04	of 9	From:	TW-07/08	To:	TW-05	Last Const.:	11/1/2016	
Surface:	AC	Family:	_MDT2024 - TW AC	Zone:		Category:		Rank:	P
Area:	28,831 SqFt	Length:	933 Ft	Width:	35 Ft				
Slabs:		Slab Length:	Ft	Slab Width:	Ft	Joint Length:	Ft		
Shoulder:		Street Type:		Grade:	0	Lanes:	0		
Section Comments:									
Work Date:	7/31/1990	Work Type:	New Construction - AC		Code:	NC-AC	Is Major M&R:	True	
Work Date:	11/1/2016	Work Type:	Complete Reconstruction - AC		Code:	CR-AC	Is Major M&R:	True	
Last Insp. Date:	10/7/2024	TotalSamples:	5	Surveyed:	3				
Conditions:	PCI: 89								
Inspection Comments:									
Sample Number:	01	Type:	R	Area:	5388.00 SqFt	PCI:	86		
Sample Comments:									
48	L & T CR	L	30.00	Ft					
57	WEATHERING	L	5119.00	SqFt					
57	WEATHERING	M	269.00	SqFt					
Sample Number:	02	Type:	R	Area:	5028.00 SqFt	PCI:	91		
Sample Comments:									
57	WEATHERING	L	4777.00	SqFt					
57	WEATHERING	M	251.00	SqFt					
Sample Number:	04	Type:	R	Area:	6560.00 SqFt	PCI:	91		
Sample Comments:									
57	WEATHERING	L	6232.00	SqFt					
57	WEATHERING	M	328.00	SqFt					

Network:	EKS	Name:	Ennis - Big Sky Airport							
Branch:	TW	Name:	Taxiway	Use:	TAXIWAY	Area:	545,239 SqFt			
Section:	05	of	9	From:	South	To:	North	Last Const.:	1/1/2020	
Surface:	AC	Family:	_MDT2024 - TW AC		Zone:		Category:		Rank:	P
Area:	344,557 SqFt	Length:	7,588 Ft	Width:	52 Ft					
Slabs:		Slab Length:	Ft	Slab Width:	Ft	Joint Length:	Ft			
Shoulder:		Street Type:		Grade:	0	Lanes:	0			
Section Comments:	Taxiway runs alongside of Runway Formerly split up into TW-01, -02, and -03.									
Work Date:	1/1/2020	Work Type:	New Construction - AC		Code:	NC-AC	Is Major M&R:	True		
Last Insp. Date:	10/7/2024	Total Samples:	68		Surveyed:	7				
Conditions:	PCI: 90									
Inspection Comments:										
Sample Number:	11	Type:	R	Area:	5200.00 SqFt	PCI:	94			
Sample Comments:										
57	WEATHERING	L		5200.00	SqFt					
Sample Number:	23	Type:	R	Area:	5200.00 SqFt	PCI:	89			
Sample Comments:										
48	L & T CR	L		50.00	Ft					
57	WEATHERING	L		5200.00	SqFt					
Sample Number:	35	Type:	R	Area:	5200.00 SqFt	PCI:	94			
Sample Comments:										
57	WEATHERING	L		5200.00	SqFt					
Sample Number:	46	Type:	R	Area:	5200.00 SqFt	PCI:	94			
Sample Comments:										
57	WEATHERING	L		5200.00	SqFt					
Sample Number:	54	Type:	R	Area:	4000.00 SqFt	PCI:	81			
Sample Comments:										
48	L & T CR	L		40.00	Ft					
57	WEATHERING	L		3200.00	SqFt					
57	WEATHERING	M		800.00	SqFt					
Sample Number:	59	Type:	R	Area:	4000.00 SqFt	PCI:	86			
Sample Comments:										
48	L & T CR	L		100.00	Ft					
57	WEATHERING	L		4000.00	SqFt					
Sample Number:	66	Type:	R	Area:	5200.00 SqFt	PCI:	92			
Sample Comments:										
48	L & T CR	L		6.00	Ft					
57	WEATHERING	L		5200.00	SqFt					

Network:	EKS	Name:	Ennis - Big Sky Airport					
Branch:	TW	Name:	Taxiway	Use:	TAXIWAY	Area:	545,239 SqFt	
Section:	06	of 9	From:	TW-05	To:	RW16	Last Const.:	1/1/2020
Surface:	AC	Family:	_MDT2024 - TW AC	Zone:		Category:	Rank:	P
Area:	20,439 SqFt	Length:	240 Ft	Width:	60 Ft			
Slabs:		Slab Length:	Ft	Slab Width:	Ft	Joint Length:	Ft	
Shoulder:		Street Type:		Grade:	0	Lanes:	0	
Section Comments:								
Work Date:	1/1/2020	Work Type:	New Construction - AC		Code:	NC-AC	Is Major M&R:	True
Last Insp. Date:	10/7/2024	TotalSamples:	4		Surveyed:	3		
Conditions:	PCI: 88							
Inspection Comments:								
Sample Number:	02	Type:	R	Area:	5090.00 SqFt	PCI:	89	
Sample Comments:								
48	L & T CR	L	77.00	Ft				
57	WEATHERING	L	5090.00	SqFt				
Sample Number:	03	Type:	R	Area:	5326.00 SqFt	PCI:	89	
Sample Comments:								
48	L & T CR	L	49.00	Ft				
57	WEATHERING	L	5326.00	SqFt				
Sample Number:	04	Type:	R	Area:	5113.00 SqFt	PCI:	87	
Sample Comments:								
48	L & T CR	L	119.00	Ft				
57	WEATHERING	L	5113.00	SqFt				

Network:	EKS	Name:	Ennis - Big Sky Airport					
Branch:	TW	Name:	Taxiway	Use:	TAXIWAY	Area:	545,239 SqFt	
Section:	07	of 9	From:	TW-04	To:	End	Last Const.:	1/1/2020
Surface:	AC	Family:	_MDT2024 - TW AC		Zone:		Category:	
Area:	16,429 SqFt	Length:	632 Ft	Width:	26 Ft			
Slabs:		Slab Length:	Ft	Slab Width:	Ft	Joint Length:	Ft	
Shoulder:		Street Type:		Grade:	0	Lanes:	0	
Section Comments:								
Work Date:	1/1/2020	Work Type:	New Construction - AC		Code:	NC-AC	Is Major M&R:	True
Last Insp. Date:	10/7/2024	Total Samples:	3	Surveyed:	2			
Conditions:	PCI: 94							
Inspection Comments:								
Sample Number:	02	Type:	R	Area:	5460.00 SqFt	PCI:	94	
Sample Comments:								
57	WEATHERING	L		5460.00 SqFt				
Sample Number:	03	Type:	R	Area:	5460.00 SqFt	PCI:	94	
Sample Comments:								
57	WEATHERING	L		5460.00 SqFt				

Network:	EKS	Name:	Ennis - Big Sky Airport					
Branch:	TW	Name:	Taxiway	Use:	TAXIWAY	Area:	545,239 SqFt	
Section:	08	of 9	From:	TW-04	To:	End	Last Const.:	1/1/2020
Surface:	AC	Family:	_MDT2024 - TW AC	Zone:		Category:	Rank:	P
Area:	28,685 SqFt	Length:	630 Ft	Width:	42 Ft			
Slabs:		Slab Length:	Ft	Slab Width:	Ft	Joint Length:	Ft	
Shoulder:		Street Type:		Grade:	0	Lanes:	0	
Section Comments:								
Work Date:	1/1/2020	Work Type:	New Construction - AC	Code:	NC-AC	Is Major M&R:	True	
Last Insp. Date:	10/7/2024	TotalSamples:	6	Surveyed:	3			
Conditions:	PCI: 90							
Inspection Comments:								
Sample Number:	02	Type:	R	Area:	4696.00 SqFt	PCI:	90	
Sample Comments:								
48	L & T CR	L	31.00	Ft				
57	WEATHERING	L	4696.00	SqFt				
Sample Number:	03	Type:	R	Area:	6219.00 SqFt	PCI:	90	
Sample Comments:								
48	L & T CR	L	21.00	Ft				
57	WEATHERING	L	6219.00	SqFt				
Sample Number:	05	Type:	R	Area:	4036.00 SqFt	PCI:	89	
Sample Comments:								
48	L & T CR	L	38.00	Ft				
57	WEATHERING	L	4036.00	SqFt				

Network: EKS **Name:** Ennis - Big Sky Airport

Branch: TW **Name:** Taxiway **Use:** TAXIWAY **Area:** 545,239 SqFt

Section: 09 of 9 **From:** - **To:** - **Last Const.:** 1/1/2016

Surface: AC **Family:** _MDT2024 - TW AAC **Zone:** **Category:** **Rank:** P

Area: 28,685 SqFt **Length:** 630 Ft **Width:** 42 Ft

Slabs: **Slab Length:** Ft **Slab Width:** Ft **Joint Length:** Ft

Shoulder: **Street Type:** **Grade:** 0 **Lanes:** 0

Section Comments:

Work Date: 1/1/2016 **Work Type:** New Construction - AC **Code:** NC-AC **Is Major M&R:** True

Work Date: 1/1/2022 **Work Type:** Surface Treatment - Seal Coat **Code:** ST-SC **Is Major M&R:** False

Last Insp. Date: 10/7/2024 **TotalSamples:** 8 **Surveyed:** 2

Conditions: PCI: 91

Inspection Comments:

Sample Number: 03 **Type:** R **Area:** 6400.00 SqFt **PCI:** 91

Sample Comments:

57 WEATHERING L 6080.00 SqFt

57 WEATHERING M 320.00 SqFt

Sample Number: 08 **Type:** R **Area:** 6743.00 SqFt **PCI:** 91

Sample Comments:

57 WEATHERING L 6406.00 SqFt

57 WEATHERING M 337.00 SqFt